

PID Temperature Controller - Single Display

PID-911, 711 & 411

Features

- Multi Sensor Input - J/K or PT-100
- Economical & Easy to Use Model
- PID and ON-OFF Control Action
- 3 Digit 0.56inch* Bright LED Display with RED and WHITE color option.

TECHNICAL SPECIFICATION

INPUT SPECIFICATION:

Input Types	Input	Range
	J / K	J: 0 to 850°C, K: 0 to 999°C
	PT-100 2W/3W	PT-100: -50 to 400°C
Resolution	1°C for (J,K), 0.1°C (PT-100)	
Indication Accuracy	±1% of FSD ± 1°C (FSD:- Full Scale Deflection)	

DISPLAY

Display	0.56 Inch 3 Digit, Single Line, 7 Segment LED
---------	---

DIMENSION:

Size (mm)	48 (H) x 48 (W) x 50 (D) mm
Panel Cutout	44 (H) x 44 (W) mm

CONTROL ACTION

Control Mode	PID or ON-OFF
--------------	---------------

OUTPUT SPECIFICATION:

Relay	1 Nos
Relay Type	1C/O (NO-C-NC)
Rating	10A (Resistive Load)

POWER SUPPLY:

Supply Voltage	110V to 270V AC, 50-60Hz
Power Consumption (VA Rating)	4VA @ 230V AC MAX

ENVIRONMENT CONDITION:

Operating Temp.	0°C to 55°C
Relative Humidity	UP to 95% RH (non-condensing)
Protection Level (As per request)	IP-65 (Front side) As per IS/IEC 60529 : 2001

KEY OPERATION

Key	Function
	SET Key (Long Press to Enter Set Point Menu)
	UP Key (To increase the value/navigate in menu)
	Down Key (To decrease the value/navigate in menu)

MECHANICAL DIMENSIONS

Dimensions for PID-411

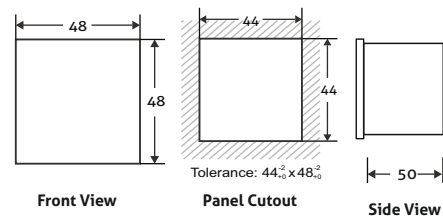

INSTALLATION

For installing the meter

- Prepare the panel cutout with proper dimensions as shown above.
- Push the meter into the panel cutout. Secure the meter in its place by fitting the clamp on the rear side. Fit the clamps on both the sides in diagonally opposite location for optimum fitting.
- For proper sealing, tighten the screws evenly with required torque.

Terminal screw tightening torque:

0.68 Nm to 0.79 Nm (6.018ln-Lb to 6.992 ln-Lb)
Screw clamp tightening torque: 0.1N-m (0.885 Lb-inch)

SAFETY PRECAUTIONS :

All safety related conditions, symbols and instruction that appear in this operating manual or on the equipment must be strictly followed to ensure the safety of the operating personnel as well as the instrument.

If the equipment is not used in a manner specified by the manufacturer it might impair the protection provided by the equipment.

- Do not use the equipment if there is any mechanical damage
- Ensure that the equipment is supplied with correct voltage

If there is physical damage to the unit then do not use it.

Read complete instruction prior to installation and operation of the unit.

Wiring Guidelines:

CAUTION :



- To prevent the risk of electric shock power supply to the equipment must be kept OFF while doing the wiring arrangement.
- Wiring shall be done strictly accordingly to the terminal layout with the shortest connection. Confirm that all connection are correct.

INSTRUMENT CONFIGURATION

ERROR CONDITIONS

- If the display shows below message

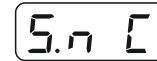

It means Input **Sensor Not Connected** or any error with connected sensor. In such case please check the sensor connections

- If the display shows below message

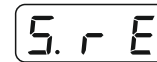

This means Input **Sensor Reverse**; In such case please check the sensor connections

FRONT PANEL DESCRIPTION

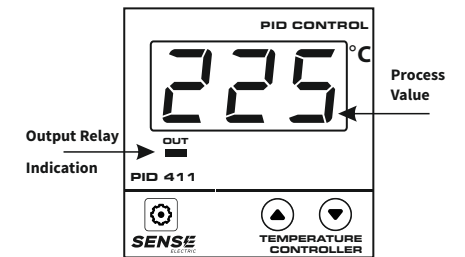

TERMINAL DIAGRAM

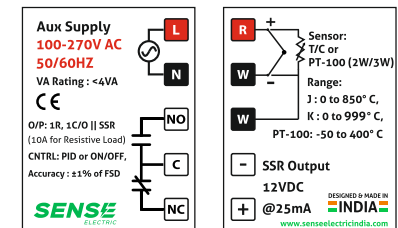

BASIC PARAMETER SETTINGS

SET POINT MENU

Long press  key to enter Set Point Menu

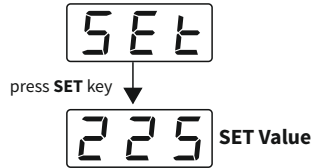

Using up & down key to change SET point
Press the SET key it will store the latest SET Value

**** Important Note:**

- Range for J Type Input : 0 to 600°C
- Range for K Type Input : 0 to 999°C
- Range for PT 100 Input : -50 to 400°C

***Note:** If the instruments stays in idle condition while inside the Configuration Menu for more than **30 seconds**, then it will automatically exit the configuration menu.

***Installation Note:**

It is been advised that the settings should be done by a professional, after going through user operating manual and after having understood the application.

ORDERING CODE

Order Code	Technical Specifications
PID 411-R	RED Display Input: Thermocouple J/K or PT-100 2W/3W (Selectable) Size: 48x48mm, PID / ON-OFF Control, Supply: 100-270V AC
PID 411-W	WHITE Display Input: Thermocouple J/K or PT-100 2W/3W (Selectable) Size: 48x48mm, PID / ON-OFF Control, Supply: 100-270V AC

Menu Name

Long press  key to enter the parameter setting menu

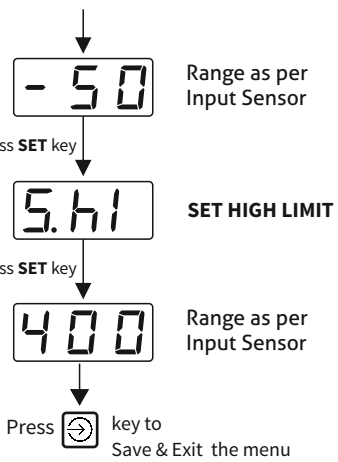
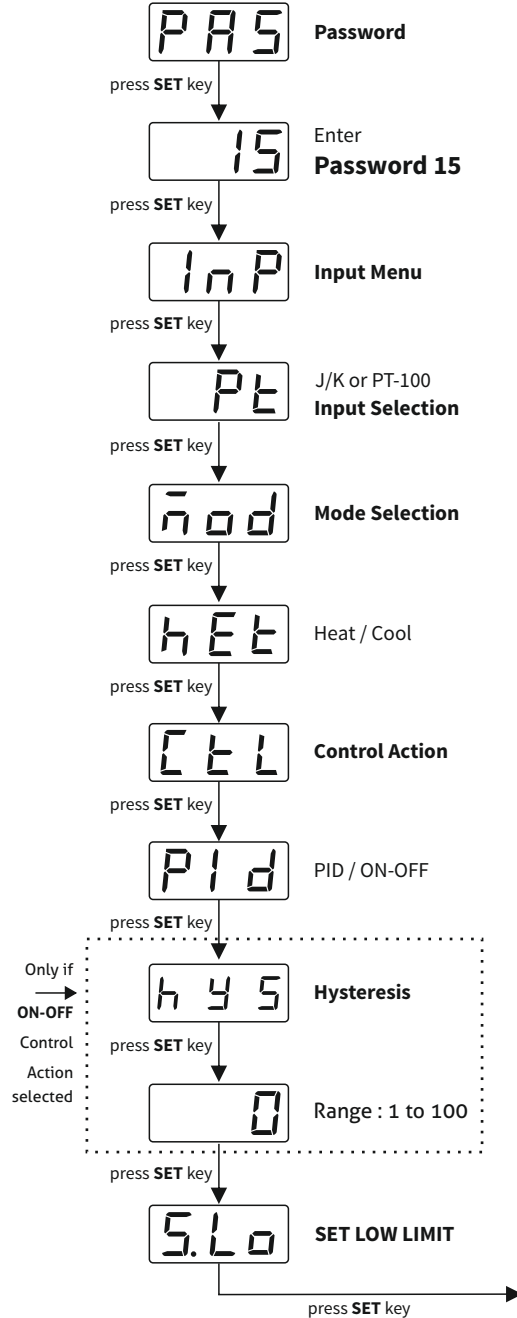

PID SETTING MENU

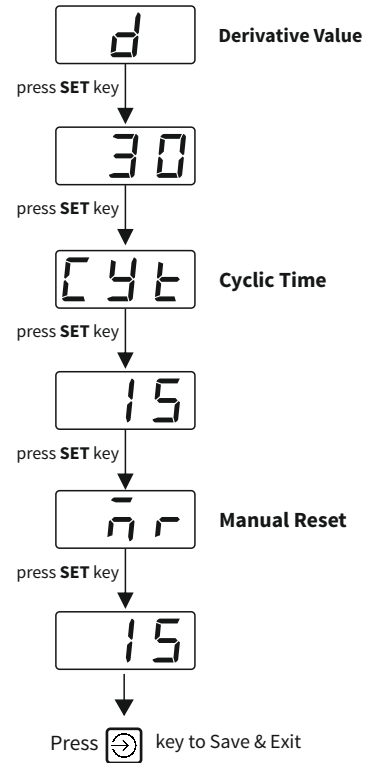
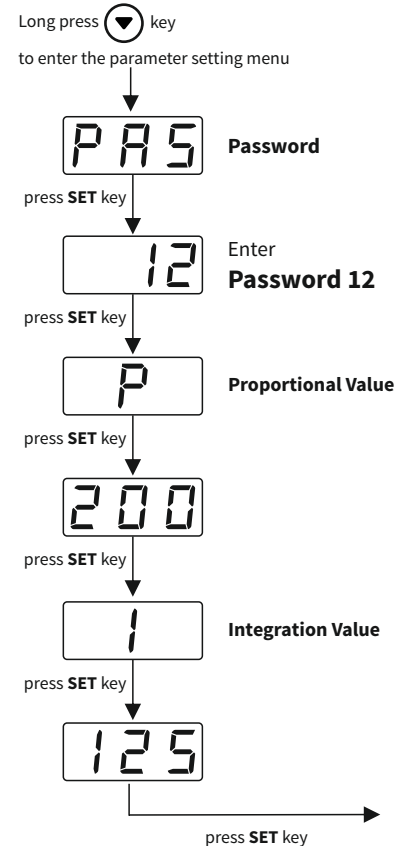

AUTO TUNE

The Auto-tuning function computes and sets the Proportional band (Pb), Integral time (It), Derivative time (dt), and cycle time automatically based on process characteristics. If the power is turned off before auto-tuning is finished, it will be restarted when the power is turned back on. Press  key for 6 Seconds to Start / Stop PID Auto Tuning

Designed & Manufactured in India

Product up-gradation is a continuous process. Hence, data in this manual is subject to change without prior notice. For latest information, please get in touch with our Sales Office.



Cosfi Electric Pvt Ltd

5 Gajanand Industrial Estate, S. P. Ring Road, Vinzol, Ahmedabad, Gujarat - India

+91 - 9909617722, 9979798775

care@senseelectricindia.com

www.senseelectricindia.com