

**Environmental Conditions**

- Indoor use
- Altitude of upto 2000 meters
- Pollution degree II
- Temperature : Operating: 0° C to 55° C  
Storage : 0° C to 75° C
- Humidity : Upto 85% RH

Protection Class : II

Mounting : Panel Mounting

Weight : 150 gms

**For installing the meter:**

1. Prepare the panel cutout with proper dimensions as shown above.
2. Push the meter into the panel cutout. Secure the meter in it's place by fitting the clamp on the rear side. Fit the clamps on both the sides in diagonally opposite location for optimum fitting.
3. For proper sealing, tighten the screws evenly with required torque.

**Terminal screw tightening torque:**

0.68 Nm to 0.79 Nm (6.018In-Lb to 6.992 In-Lb)  
Screw clamp tightening torque: 0.1N-m (0.885 Lb-inch)

**SAFETY PRECAUTIONS :**

All safety related conditions, symbols and instruction that appear in this operating manual or on the equipment must be strictly followed to ensure the safety of the operating personnel as well as the instrument.

If the equipment is not used in a manner specified by the manufacturer it might impair the protection provided by the equipment.

- ◆ Do not use the equipment if there is any mechanical damage
- ◆ Ensure that the equipment is supplied with correct voltage

If there is physical damage to the unit then do not use it.

Read complete instruction prior to installation and operation of the unit.

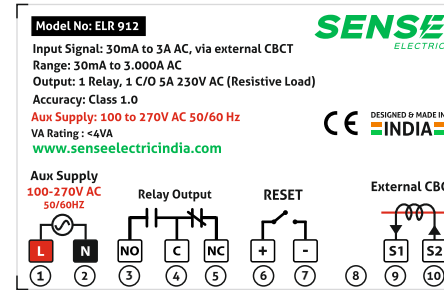

**Wiring Guidelines:**

**CAUTION :**



- 1) To prevent the risk of electric shock power supply to the equipment must be kept OFF while doing the wiring arrangement.
- 2) Wiring shall be done strictly accordingly to the terminal layout with the shortest connection. Confirm that all connection are correct.

**FRONT PANEL DESCRIPTION**

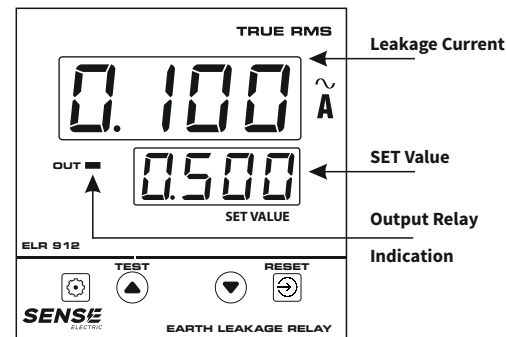

1. Prepare the panel cutout with the proper dimensions. Connect everything as shown in the connection diagram and turn on the instrument.
2. When the power is turned ON, the relay will turn ON after the **Power ON Delay Time** has been completed. This delay only works the first time when power is turned on.
3. When the current value reaches or exceeds the Set Value, the delay time begins, and if the process value exceeds the Set Value after the delay time, the relay is Turned OFF.
4. When the current value is less than the SET - Hysteresis, the relay will Turn ON.

**ELR 912**

**EARTH LEAKAGE RELAY**

**Features**

- ◆ Compact Design with Low Back Depth 40mm
- ◆ True RMS Measurement
- ◆ User Friendly & Easy to Program
- ◆ 0.8 Inch Bigger & Ultra Bright Display

**TECHNICAL SPECIFICATION**

**Display**

7 Segment LED Display, Dual Line, 4 digits each  
Digit Height: Upper 0.8 inch, Lower 0.56 inch

LED Indication for Relay Trip Indication

**Input Specifications:**

**Rated Input Current**

30mA to 3A AC, via external CBCT

Range: 30mA to 3000A AC

**Output Specifications:**

No. of Output: 1 Relay 1 C/O

Relay Rating: 5A, 230V AC (Resistive Load)

**Auxiliary Supply**

Supply Voltage: 100V to 270V AC (SMPS), 50/60 Hz

Power Consumption: <4VA @270V Max

**MENU DESCRIPTION**

| KEY PRESS            | PASSWORDS  |
|----------------------|--|
| <p>PRESS SET KEY</p> | <p><b>MENU 1</b></p> <p><b>Password 15</b></p> <p>Enter Password 15 to go into the Parameter Selection Menu.</p> |
|                      | <p><b>MENU 2</b></p> <p><b>Password 17</b></p> <p>This menu is to reset the instrument to Factory Settings.</p>  |

\*Note: If the instruments stay in idle condition while inside the **Configuration Menu** for more than 60 seconds, then it will automatically exit the configuration menu.

**\*Installation Note:**

It is been advised that the settings should be done by a professional, after going through user operating manual and after having understood the application.

## SET POINT CONFIGURATION

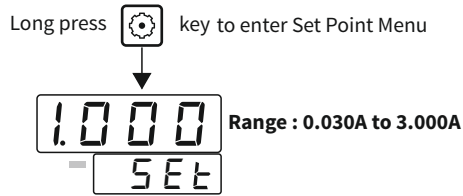

Using up & down key to change SET point  
Press the SET key it will store the latest SET Value

Long press / Key to exit the menu

## FACTORY RESET MENU

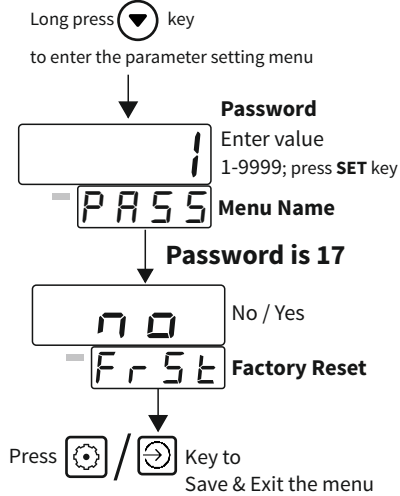

## PARAMETER SETTINGS

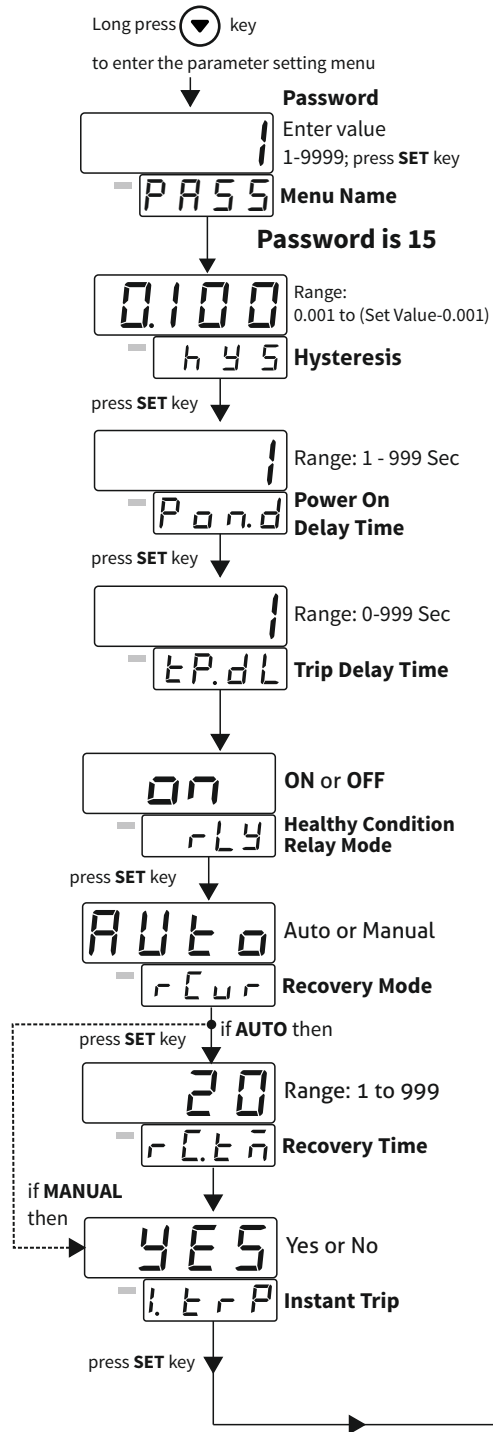

## TEST MODE

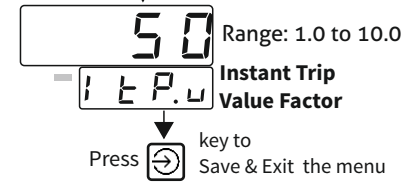

## TEST MODE

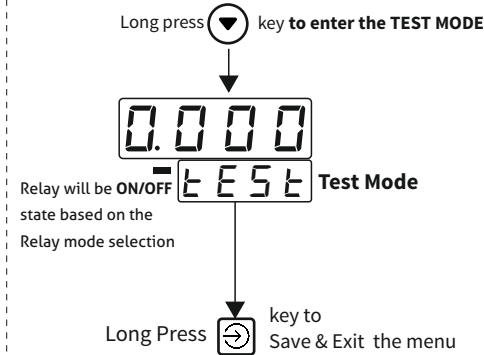

## RESET FUNCTION

There are two ways to RESET the relay contact once it trips:

### 1) Auto Reset

Healthy Condition Relay Mode = ON  
Trip Set Point = 2.000 Amp  
Hysteresis = 0.100 Amp

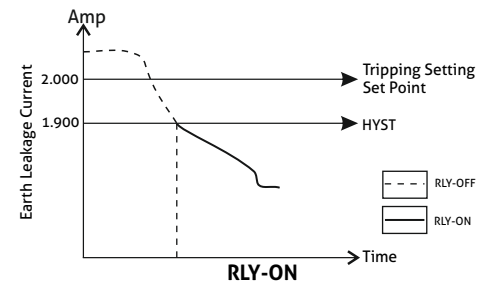

### 2) Manual Reset

NOTE: When Leakage Current < Setpoint - Hysteresis

Press key to RESET RELAY

## ALARM OPERATIONS

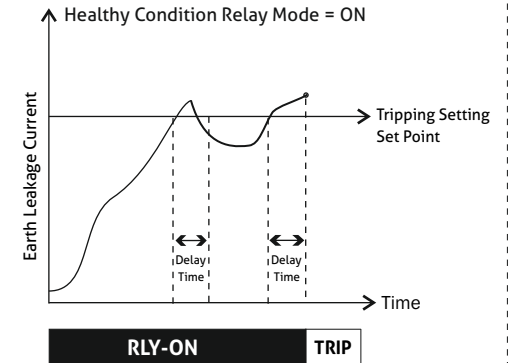

Designed & Manufactured in India

Product up-gradation is a continuous process. Hence, data in this manual is subject to change without prior notice.

For latest information, please get in touch with our Sales Office.

**SENSE**  
ELECTRIC

**Cosfi Electric Pvt Ltd**

5 Gajanand Industrial Estate, Nr. Hathijan Circle,  
S. P. Ring Road, Vinzol, Ahmedabad, Gujarat - India

+91 - 9909617722, 9979798775

care@senseelectricindia.com

www.senseelectricindia.com